

Benefits of a technological migration

From this

- Uncertainty of stock parts
- Limited communication networks
- Lack of technical support
- Risk of increased unscheduled Downtime
- No warranty coverage
- Increase maintenance costs
- Decreasing production efficiency

To this:

- Integrated architecture for increased flexibility
- Easy access to production data for better management decisions
- Quicker response to market demands
- Reduced risk of unscheduled downtime

Protect your investment with a step-by-step Migration

Phase 1

HMI replacement

A improved user interface gives you greater flexibility and control over the process and process.

Ensure product quality

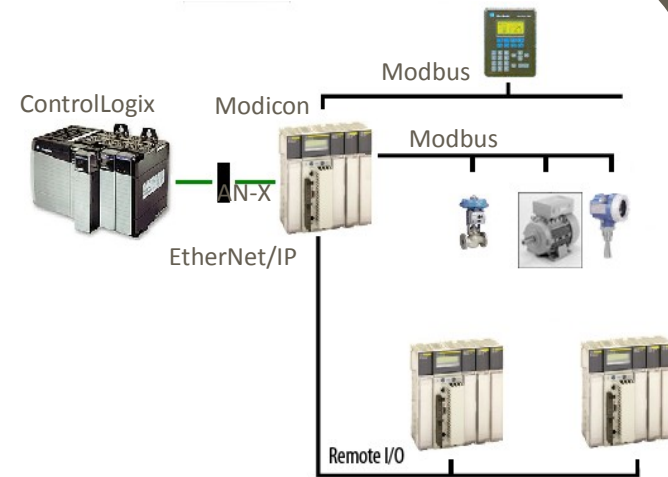

Phase 3

I/O replacement

Since replacing your I/O means big investments, we propose phased replacements (by I/O rack, for example) allowing you to closely control your budget.

I/O replacement: all at once or step-by-step

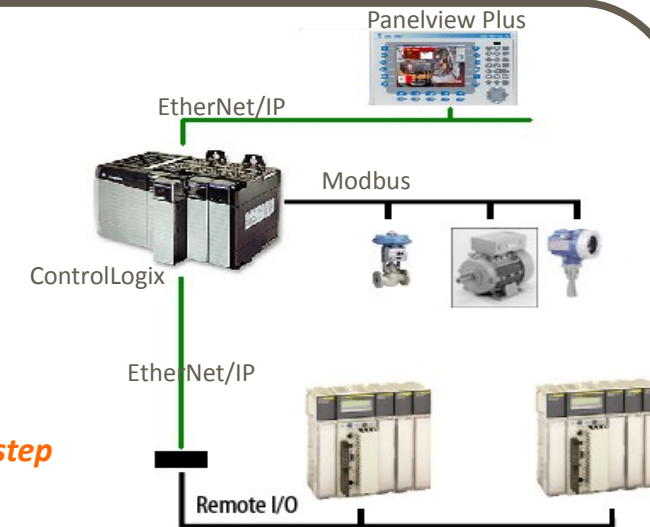

Phase 2

Controller (PLC) replacement

An up-to-date controller means:

- Improved execution cycle times
- Increase data process capability
- Expansion and integration of communication networks

Keep I/O, get in control

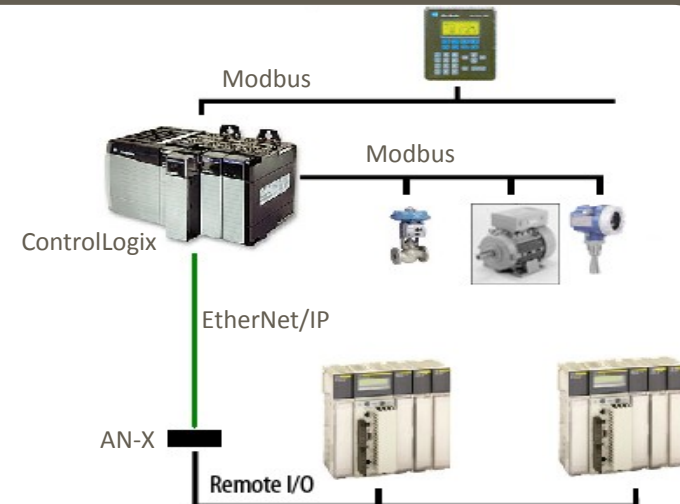

Phase 4

Process upgrade

Besides extending your control network to other controllers and process points, you have the possibility of building and Integrated Control Architecture, by connecting to corporate management systems.

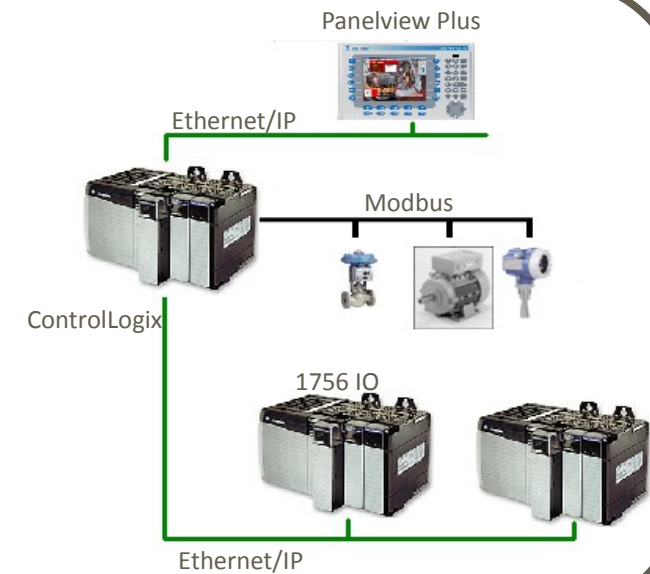

Full conversion service

1 – On-site Evaluation

- Assessment of risk and requirements
- Conversion checklists
- Elaboration of the Bill of Materials (BoM)
- Project scheduling

2 – Conversion Engineering

- HMI and/or PLC software conversion
- Documentation conversion/update
- Hardware update (optional)

3 – Start-up

- Start-up checklist
- Operating tests approved by the client
- Delivery of documentation, including plans and software.

Modicon Migrations
984/584/Quantum

www.acontrol.pt

acontrol.geral@acontrol.pt +351239918009

+351239918007

GPS: N 40°14'15.84" W 8°25'57.47"